

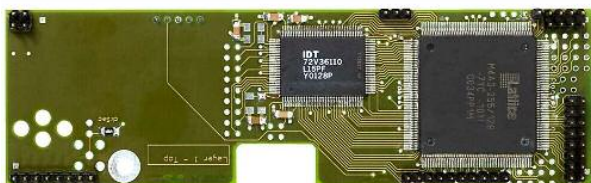

# SPECTRUM

SYSTEMENTWICKLUNG MICROELECTRONIC GMBH

## Timestamp module for all Boards of the MI.xxxx Series



- **Records time information of triggers**
- **Resolution equal to samplerate**
- **Synchronisation with radio clock or GPS**
- **Piggyback module for MI boards**
- **Available for all MI boards**
- **Large FIFO for 64k timestamps**
- **64 bit timestamps**
- **Easy programmable software interface**

### General

The timestamp module was designed to record the exact time information between trigger events.

It could be used together with the option Multiple Recording or Gated Sampling but it could also be used for standard modes. In Gated Sampling mode start and stop of the gate signal are timestamped.

The timestamp reset command sets an internal counter to zero. The counter is running with the same resolution that the samplerate has. On each trigger event a timestamp is recorded in an extra FIFO. The recorded timestamps are read out asynchronously to the board sampling.

If the absolute time information is of interest it is possible to synchronise the timestamp counter with a "seconds" signal of a radio clock or a GPS receiver. In that case the 64 bit timestamp information is split up in two parts. The one part counts the number of seconds starting with the reset command, the other part is set to zero on every edge of the seconds signal and specifies the exact time position in relation to the seconds signal.

### Hardware block diagram

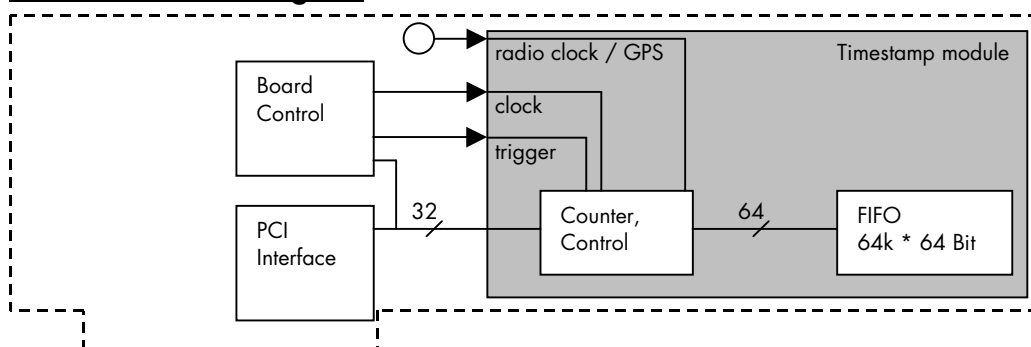

### Operating modes

#### **Standard mode**

In the standard mode the counter is reset at any time with a software command. All recordings are timestamped in relation to that start command. In this mode the time relation between different recordings could be calculated. This mode could be used with standard recording (pre- and posttrigger) as well as with Multiple Recording and Gated Sampling.

#### **StartReset mode**

On each start command the timestamp counter is set to zero. All timestamps are in relation to the start of recording. This mode is useful for Multiple Recording and Gated Sampling only.

#### **Refclock mode**

The counter is divided in two parts. The upper part counts the seconds that has elapsed since the start of the counter. The lower part counts the position in the actual second with resolution of the used clock. This mode allows recording of an absolute time at trigger event. The 1 Hz reference clock could be obtained from a radio clock or a GPS system.

If Refclock mode should be used, the connection of the signal must be discussed with Spectrum before ordering.

### Order Information

Option timestamp      Timestamp module with 64 kStamps memory

MI.xxxx-time

**It is not possible to use this option together with the star hub or extra I/O option.**

**Spectrum reserves the right to make changes at any time to improve design and to supply the best product possible**