

DN2.60x - up to 8 channel 14 bit generatorNETBOX up to 125 MS/s

- **Fast 14 bit arbitrary waveform generator**
- **4 or 8 channels with up to 125 MS/s**
- **Simultaneous arbitrary generation on all channels**
- **Output up to ± 3 V in 50 Ohm**
- **Offset and amplitude programmable**
- **3 software selectable filters**
- **512 MSample/1 GSample standard generation memory**
- **FIFO mode continuous streaming output**
- **Features: Multiple Replay, Gated Replay, Sequence Replay Mode**

New generatorNETBOX

- Bumpers
- Stackable
- Handle
- GND Screw



- Ethernet Remote Instrument
- LXI Core 2011 compatible
- GBit Ethernet Interface
- Sustained streaming mode up to 70 MB/s
- Direct Connection to PC/Laptop
- Connect anywhere in company LAN
- Embedded Webserver for Maintenance/Updates
- Embedded Server option for open Linux platform

Operating Systems

- Windows XP, Vista, 7, 8, 10
- Linux Kernel 2.6, 3.x, 4.x
- Windows/Linux 32 and 64 bit

SBench 6 Professional Included

- Acquisition, Generation and Display of analog and digital data
- Calculation, Documentation and Import, Export

Drivers

- LabVIEW, MATLAB
- IVI LabWindows/CVI
- C/C++, GNU C++, VB.NET, C#, J#, Borland Delphi, Java, Python

Model	1 channel	2 channels	4 channels	8 channels
DN2.603-04	125 MS/s	125 MS/s	62.5 MS/s	
DN2.603-08	125 MS/s	125 MS/s	125 MS/s	62.5 MS/s

General Information

The generatorNETBOX DN2.60x series allows arbitrary signal generation on up to 8 channels with update (sampling) rates of up to 62.5 MS/s or 4 channels with update rates of up to 125 MS/s. These Ethernet Remote instruments offer outstanding D/A features both in resolution and signal quality. The combination of high sampling rate and resolution makes these AWGs the top-of-the-range for mid-speed applications that require high quality signal generation. The generatorNETBOX can be installed anywhere in the company LAN and can be remotely controlled from a host PC.

Software Support

Windows Support

The digitizerNETBOX/generatorNETBOX can be accessed from Windows XP, as well as Vista, Windows 7, Windows 8, Windows 10 (each 32 bit and 64 bit). Programming examples for Visual C++, Borland C++ Builder, LabWindows/CVI, Borland Delphi, Visual Basic, VB.NET, C#, J#, Python, Java and IVI are included.

Linux Support



The digitizerNETBOX/generatorNETBOX can be accessed from any Linux system. The Linux support includes SMP systems, 32 bit and 64 bit systems, versatile programming examples for Gnu C++, Python as well as drivers for MATLAB for Linux. SBench 6, the powerful data acquisition and analysis software from Spectrum is also included as a Linux version.

Discovery Protocol

Physical Location	
Bus No	0
Device No	0
Function No	0
Slot No	0
IP	192.168.169.14
VISA	TCP/IP[0]:192.168.169.14::inst0::INSTR

The Discovery function helps you to find and identify any Spectrum LXI instruments, like the digitizerNETBOX and generatorNETBOX, available to your computer on the network. The Discovery function will also locate any Spectrum card products that are managed by an installed Spectrum Remote Server somewhere on the network.

After running the discovery function the card information is cached and can be directly accessed by SBench 6. Furthermore the qualified VISA address is returned and can be used by any software to access the remote instrument.

SBench 6 Professional

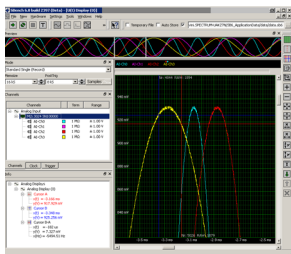

The digitizerNETBOX and generatorNETBOX can be used with Spectrum's powerful software SBench 6 – a Professional license for the software is already installed in the box. SBench 6 supports all of the standard features of the instrument. It has a variety of display windows as well as analysis, export and documentation

functions.

- Available for Windows XP, Vista, Windows 7, Windows 8, Windows 10 and Linux
- Easy to use interface with drag and drop, docking windows and context menus
- Display of analog and digital data, X-Y display, frequency domain and spread signals
- Designed to handle several GBytes of data
- Fast data preview functions

IVI Driver

The IVI standards define an open driver architecture, a set of instrument classes, and shared software components. Together these provide critical elements needed for instrument interchangeability. IVI's defined Application Programming Interfaces (APIs) standardize common measurement functions reducing the time needed to learn a new IVI instrument.

The Spectrum products to be accessed with the IVI driver can be locally installed data acquisition cards, remotely installed data acquisition cards or remote LXI instruments like digitizerNETBOX/generatorNETBOX. To maximize the compatibility with existing IVI

based software installations, the Spectrum IVI driver supports IVI Scope, IVI Digitizer and IVI FGen class with IVI-C and IVI-COM interfaces.

Third-party Software Products

Most popular third-party software products, such as LabVIEW, MATLAB or LabWindows/CVI are supported. All drivers come with examples and detailed documentation.

Embedded Webserver



Instrument Welcome Page	
Instrument Model	DN2.465-08
Manufacturer	Spectrum GmbH
Serial Number	8085
Description	DN2 prototype at developme
LXI Features	LXI Core 2011
LXI Version	LXI Device Specification 201
Host Name	192.168.169.14
mDNS Host Name	DN2_465-08_sn08085.local
MAC Address	00:03:2D:21:AE:AE
TCP/IP Address	192.168.169.14

webserver.

The integrated webserver follows the LXI standard and gathers information on the product, set up of the Ethernet configuration and current status. It also allows the setting of a configuration password, access to documentation and updating of the complete instrument firmware, including the embedded remote server and the

Hardware features and options

LXI Instrument



The digitizerNETBOX and generatorNETBOX are fully LXI instrument compatible to LXI Core 2011 following the LXI Device Specification

2011 rev. 1.4. The digitizerNETBOX/generatorNETBOX has been tested and approved by the LXI Consortium.

Located on the front panel is the main on/off switch, LEDs showing the LXI and Acquisition status and the LAN reset switch.

digitizerNETBOX/generatorNETBOX chassis version V2



The chassis version V2 got a complete re-design to allow some new features that improve the handling especially for mobile and shared usage:

- 8 bumper edges protect the chassis, the desk and other components on it. The bumper edges allow to store the chassis either vertically or horizontally and the lock-in structure allows to stack multiple chassis with a secure fit onto each other. For 19" rack mount montage the bumpers can be unmounted and replaced by the 19" rack mount option
- The handle allows to easily carry the chassis around in juts one hand.
- A standard GND screw on the back of the chassis allows to connect the metal chassis to measurement ground to reduce noise based on ground loops and ground level differences.

Front Panel



Standard BNC connectors are used for all analog input or output signals and all trigger and clock signals. No special adapter cables are needed and the connection is secure even when used in a moving environment.

Custom front panels are available on request even for small series, be it SMA, LEMO connectors or custom specific connectors.

Ethernet Connectivity



The GBit Ethernet connection can be used with COTS Ethernet cabling as well as special industrial grade Buccaneer Ethernet cables. The integration into a standard LAN allows to connect the digitizerNETBOX/generatorNETBOX either directly to a desktop PC or Laptop or it is possible

to place the instrument somewhere in the company LAN and access it from any desktop over the LAN.

DC Power Supply Option



The digitizerNETBOX/generatorNETBOX can be equipped with an internal DC power supply which replaces the standard AC power supply. Two different power supply options are available that range from 9V to 36V. Contact the sales team if other DC levels are required.

Using the DC power supply the digitizerNETBOX/generatorNETBOX can be used for mobile applications together with a Laptop in automotive or airborne applications.

Option Embedded Server

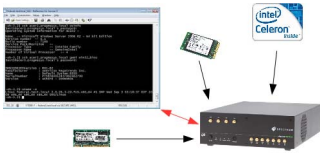

The option turns the digitizerNETBOX/generatorNETBOX in a powerful PC that allows to run own programs on a small and remote data acquisition system. The digitizerNETBOX/generatorNETBOX is enhanced by more memory, a powerful CPU, a freely accessible internal SSD and a remote software development access method.

The digitizerNETBOX/generatorNETBOX can either run connected to LAN or it can run totally independent, storing data to the internal SSD. The original digitizerNETBOX/generatorNETBOX remote instrument functionality is still 100% available. Running the embedded server option it is possible to pre-calculate results based on the acquired data, store acquisitions locally and to transfer just the required data or results parts in a client-server based software structure. A different example for the digitizerNETBOX/generatorNETBOX embedded server is surveillance/logger application which can run totally independent for days and send notification emails only over LAN or offloads stored data as soon as it's connected again.

Access to the embedded server is done through a standard text based Linux shell based on the ssh secure shell.

Access to the embedded server is done through a standard text based Linux shell based on the ssh secure shell.

Singleshot output

When singleshot output is activated the data of the on-board memory is played exactly one time. The trigger source can be either one of the external trigger inputs or the software trigger. After the first trigger additional trigger events will be ignored.

Repeated output

When the repeated output mode is used the data of the on-board memory is played continuously for a programmed number of times or until a stop command is executed. The trigger source can be either one of the external trigger inputs or the software trigger. After the first trigger additional trigger events will be ignored.

Single Restart replay

When this mode is activated the data of the on-board memory will be replayed once after each trigger event. The trigger source can be either the external TTL trigger or software trigger.

FIFO mode

The FIFO mode is designed for continuous data transfer between remote instrument and PC memory or hard disk. The control of the data stream is done automatically by the driver on interrupt request. The complete installed on-board memory is used for buffer data, making the continuous streaming extremely reliable.

Multiple Replay

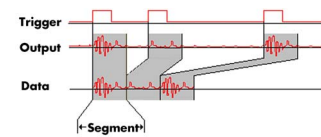

The Multiple Replay mode allows the fast output generation on several trigger events without restarting the hardware. With this option very fast repetition rates can be achieved. The on-board memory is divided into several segments of the same size. Each segment can contain different data which will then be played with the occurrence of each trigger event.

Gated Replay

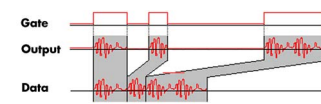

The Gated Sampling mode allows data replay controlled by an external gate signal. Data is only replayed if the gate signal has attained a

programmed level.

Sequence Mode

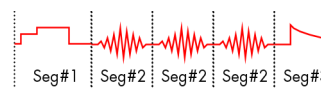

The sequence mode allows to split the card memory into several data segments of different length. These data segments are chained up in a user chosen order using an additional sequence memory. In this sequence memory the number of loops for each segment can be programmed and trigger conditions can be defined to proceed from segment to segment. Using the sequence mode it is also possible to switch between replay waveforms by a simple software command or to redefine waveform data for segments simultaneously while other segments are being replayed.

External trigger I/O

External trigger I/O

All digital boards can be triggered using an additional external TTL signal per acquisition module. It's possible to use positive or negative edge also in combination with a programmable pulse width. An internally recognized trigger event can - when activated by software - be routed to the trigger output connector to start external instruments.

Pulse width

Defines the minimum or maximum width that a trigger pulse must have to generate a trigger event. Pulse width can be combined with channel trigger, pattern trigger and external trigger.

External clock I/O

Using a dedicated line a sampling clock can be fed in from an external system. It's also possible to output the internally used sampling clock to synchronize external equipment to this clock.

Reference clock

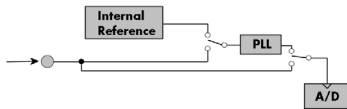

The option to use a precise external reference clock (normally 10 MHz) is necessary to synchronize the instrument for high-quality measurements with external equipment (like a signal source). It's also possible to enhance the quality of the sampling clock in this way. The driver automatically generates the requested sampling clock from the fed in reference clock.

Technical Data

Analog Outputs

Resolution		14 bit
Output amplitude	software programmable	± 100 mV up to ± 3 V in 1 mV steps (Amp option: ± 333 mV up to ± 10 V in 3 mV steps)
Output offset	software programmable	± 3 V in 1 mV steps (Amp option: ± 10 V in 3 mV steps)
Filters	software programmable	no filter or one of 3 different filters as defined in technical data section
DAC Differential non linearity (DNL)	DAC only	± 1.5 LSB typical
DAC Integral non linearity (INL)	DAC only	± 1.0 LSB typical
Output resistance		< 1 Ohm
Minimum output load		35 Ohm (not short circuit protected)
Max output swing in 50 Ohm		± 3 V (offset + amplitude)
Max slew rate (no filter)		> 0.9 V/ns
Crosstalk @ 1 MHz signal ± 3 V		< -80 dB
Output accuracy		< 1%

Trigger

Running mode	software programmable	Singleshot, FIFO mode (Streaming), Repeated Replay, Single Restart, Sequence Mode
Trigger edge	software programmable	Rising edge, falling edge or both edges
Trigger pulse width	software programmable	0 to [64k - 1] samples in steps of 1 sample
Trigger delay	software programmable	0 to [64k - 1] samples in steps of 1 sample
Memory depth	software programmable	8 up to [installed memory / number of active channels] samples in steps of 4
Multiple Replay segment size	software programmable	8 up to [installed memory / 2 / active channels] samples in steps of 4
Multiple Replay, Gated Replay: re-arming time		< 4 samples
Trigger output delay		One positive edge after internal trigger event
Internal/External trigger accuracy		1 sample
External trigger type (input and output)		3.3V LVTTTL compatible (5V tolerant)
External trigger input		Low ≤ 0.8 V, High ≥ 2.0 V, ≥ 8 ns in pulse stretch mode, ≥ 2 clock periods all other modes
External trigger maximum voltage		-0.5 V up to +5.7 V (internally clamped to 5.0V, 100 mA max. clamping current)
Trigger impedance	software programmable	50 Ohm / high impedance (> 4kOhm)
External trigger output type		3.3 V LVTTTL
External trigger output levels		Low ≤ 0.4 V, High ≥ 2.4 V, TTL compatible
External trigger output drive strength		Capable of driving 50 ohm load, maximum drive strength ± 128 mA
Output delay trigger to 1st sample		15/16 clocks (2/1 channel/module)
Gate end to last replayed sample		15/16 clocks (2/1 channel/module)
Gate end alignment		2 samples (1 ch), 1 sample (2 or 4 ch)

Clock

Clock Modes	software programmable	internal PLL, internal quartz, external clock, external divided, external reference clock, sync
Internal clock range (PLL mode)	software programmable	1 kS/s to max using internal reference, 50kS/s to max using external reference clock
Internal clock accuracy		≤ 20 ppm
Internal clock setup granularity		$\leq 1\%$ of range (100M, 10M, 1M, 100k,...): Examples: range 1M to 10M: stepsize $\leq 100k$
External reference clock range	software programmable	≥ 1.0 MHz and ≤ 125.0 MHz
External clock impedance	software programmable	50 Ohm / high impedance (> 4kOhm)
External clock range		see „Dynamic Parameters“ table below
External clock delay to internal clock		5.4 ns
External clock type/edge		3.3V LVTTTL compatible, rising edge used
External clock input		Low level ≤ 0.8 V, High level ≥ 2.0 V, duty cycle: 45% - 55%
External clock maximum voltage		-0.5 V up to +3.8 V (internally clamped to 3.3V, 100 mA max. clamping current)
External clock output type		3.3 V LVTTTL
External clock output levels		Low ≤ 0.4 V, High ≥ 2.4 V, TTL compatible
External clock output drive strength		Capable of driving 50 ohm load, maximum drive strength ± 128 mA
Synchronization clock divider	software programmable	2 up to [8k - 2] in steps of 2
ABA mode clock divider for slow clock	software programmable	8 up to 524280 in steps of 8

Clock and Filter

	M2i.6011 M2i.6012	M2i.6021 M2i.6022	M2i.6030 M2i.6031 M2i.6033 M2i.6034 DN2.603-xx
max internal clock	20 MS/s	62.5 MS/s	125 MS/s
max external clock	20 MS/s	62.5 MS/s	125 MS/s
-3 dB bandwidth no filter	> 10 MHz	> 30 MHz	> 60 MHz
Filter 3: Characteristics	4th order Butterworth		5th order Butterworth
Filter 3: -3 dB bandwidth	5 MHz (typ. 5.4 MHz)	10 MHz (typ. 11.4 MHz)	25 MHz (typ. 26.5 MHz)
Filter 2: Characteristics	4th order Butterworth		4th order Butterworth
Filter 2: -3 dB bandwidth	1 MHz (typ. 1.2 MHz)	2 MHz (typ. 2.4 MHz)	5 MHz (typ. 5.8 MHz)
Filter 1: Characteristics	4th order Butterworth		4th order Butterworth
Filter 1: -3 dB bandwidth	100 kHz (typ. 96 kHz)	200 kHz (typ. 200 kHz)	500 kHz (typ. 495 kHz)

Sequence Replay Mode

Number of sequence steps	software programmable	1 up to 512 (sequence steps can be overloaded at runtime)
Number of memory segments	software programmable	2 up to 256 (segment data can be overloaded at runtime)
Loop Count	software programmable	1 to 1M loops
Sequence Step Commands	software programmable	Loop for #Loops, Next, Loop until Trigger, End Sequence
Special Commands	software programmable	Data Overload at runtime, sequence steps overload at runtime

Connectors

Analog Inputs		9 mm BNC female (one for each single-ended input)	Cable-Type: Cab-9m-xx-xx
Trigger A Input/Output	programmable direction	9 mm BNC female	Cable-Type: Cab-9m-xx-xx
Trigger B Input		9 mm BNC female	Cable-Type: Cab-9m-xx-xx
Clock Input/Output	programmable direction	9 mm BNC female	Cable-Type: Cab-9m-xx-xx

Environmental and Physical Details DN2.xxx

Dimension of Chassis without connectors or bumpers	L x W x H	366 mm x 267 mm x 87 mm
Dimension of Chassis with 19" rack mount option	L x W x H	366 mm x 482.6 mm x 87 mm (2U height)
Weight (4 and 8 channels version)		6.3 kg, with rack mount kit: 6.8 kg
Weight (16 channels version)		6.7 kg, with rack mount kit 7.2 kg
Warm up time		10 minutes
Operating temperature		0°C to 50°C
Storage temperature		-10°C to 70°C
Humidity		10% to 90%

Option digitizerNETBOX/generatorNETBOX embedded server (DN2.xxx-Emb, DN6.xxx-Emb)

CPU	Intel Quad Core 2 GHz
System memory	4 GByte RAM
System data storage	Internal 128 GByte SSD
Development access	Remote Linux command shell (ssh), no graphical GUI available
Accessible Hardware	Full access to Spectrum instruments, LAN, front panel LEDs, RAM, SSD
Integrated operating system	OpenSuse 12.2 with kernel 3.4.6.

Ethernet specific details

LAN Connection	Standard RJ45 or Ethernet Buccaneer(R) for screw connection
LAN Speed	Auto Sensing: GBit Ethernet, 100BASE-T, 10BASE-T
Used LAN Ports	Webserver: 80 mDNS Daemon: 5353 VISA Discovery Protocol: 111, 9757 UPNP Daemon: 1900 Spectrum Remote Server: 1026, 5025

Power connection details

Mains AC power supply	Input voltage: 90 to 264 VAC, 50 to 60 Hz
AC power supply connector	IEC 60320-1-C14 (PC standard coupler)
Power supply cord	power cord included for Schuko contact (CEE 7/7)

Certification, Compliance, Warranty

EMC Immunity	Compliant with CE Mark
EMC Emission	Compliant with CE Mark
Product warranty	2 years starting with the day of delivery
Software and firmware updates	Life-time, free of charge

Power Consumption

	230 VAC		12 VDC		24 VDC	
4 channel version, standard memory	TBD	TBD	TBD	TBD	TBD	TBD
8 channel version, standard memory	TBD	TBD	TBD	TBD	TBD	TBD
4 channel version, 1 x 2 GSample memory	TBD	TBD	TBD	TBD	TBD	TBD
8 channel version, 1 x 2 GSample memory	TBD	TBD	TBD	TBD	TBD	TBD

MTBF

MTBF 100000 hours

Dynamic Parameters

	M2i.6011 M2i.6012	M2i.6011 M2i.6012	M2i.6011 M2i.6012	M2i.6021 M2i.6022	M2i.6021 M2i.6022	M2i.6030 M2i.6031 M2i.6033 M2i.6034 DN2.603-xx	M2i.6030 M2i.6031 M2i.6033 M2i.6034 DN2.603-xx	M2i.6030 M2i.6031 M2i.6033 M2i.6034 DN2.603-xx	M2i.6030 M2i.6031 M2i.6033 M2i.6034 DN2.603-xx
max internal / external clock	20 MS/s	20 MS/s	20 MS/s	60 MS/s	60 MS/s	62.5 MS/s	62.5 MS/s	125 MS/s	125 MS/s
min internal clock	1 kS/s	1 kS/s	1 kS/s	1 kS/s	1 kS/s	1 kS/s	1 kS/s	1 kS/s	1 kS/s
min external clock	DC	DC	DC	DC	DC	DC	DC	DC	DC
Test - Samplerate	20 MS/s	20 MS/s	20 MS/s	60 MS/s	60 MS/s	62.5 MS/s	62.5 MS/s	125 MS/s	125 MS/s
Output Frequency	80 kHz	800 kHz	4 MHz	170 kHz	1.7 MHz	400 kHz	4 MHz	400 kHz	4 MHz
Output Level	±2 V	±2 V	±2 V	±2 V	±2 V	±2 V	±2 V	±2 V	±2 V
Used Filter	100 kHz	1 MHz	5 MHz	200 kHz	2 MHz	500 kHz	5 MHz	500 kHz	5 MHz
SNR (typ)	> 61.5 dB	> 60.2 dB	> 54.5 dB	> 61.5 dB	> 59.5 dB	> 61.5 dB	> 55.0 dB	> 61.0 dB	> 56.0 dB
THD (typ)	< -70.4 dB	< -67.5 dB	< -45.0 dB	< -72.7 dB	< -62.5 dB	< -71.5 dB	< -55.6 dB	< -71.5 dB	< -56.0 dB
SFDR (typ), excl harm.	> 85.5 dB	> 72.0 dB	> 60.0 dB	> 81.5 dB	> 68.5 dB	> 82.8 dB	> 66.5 dB	> 72.0 dB	> 67.0 dB

Dynamic parameters are measured at ± 1 V input range (if no other range is stated) and 50 Ohm termination with the samplerate specified in the table. Measured parameters are averaged 20 times to get typical values. Test signal is a pure sine wave of the specified frequency with > 99% amplitude. SNR and RMS noise parameters may differ depending on the quality of the used PC. SNR = Signal to Noise Ratio, THD = Total Harmonic Distortion, SFDR = Spurious Free Dynamic Range, SINAD = Signal Noise and Distortion, ENOB = Effective Number of Bits. For a detailed description please see application note 002.

Block diagram of generatorNETBOX DN2

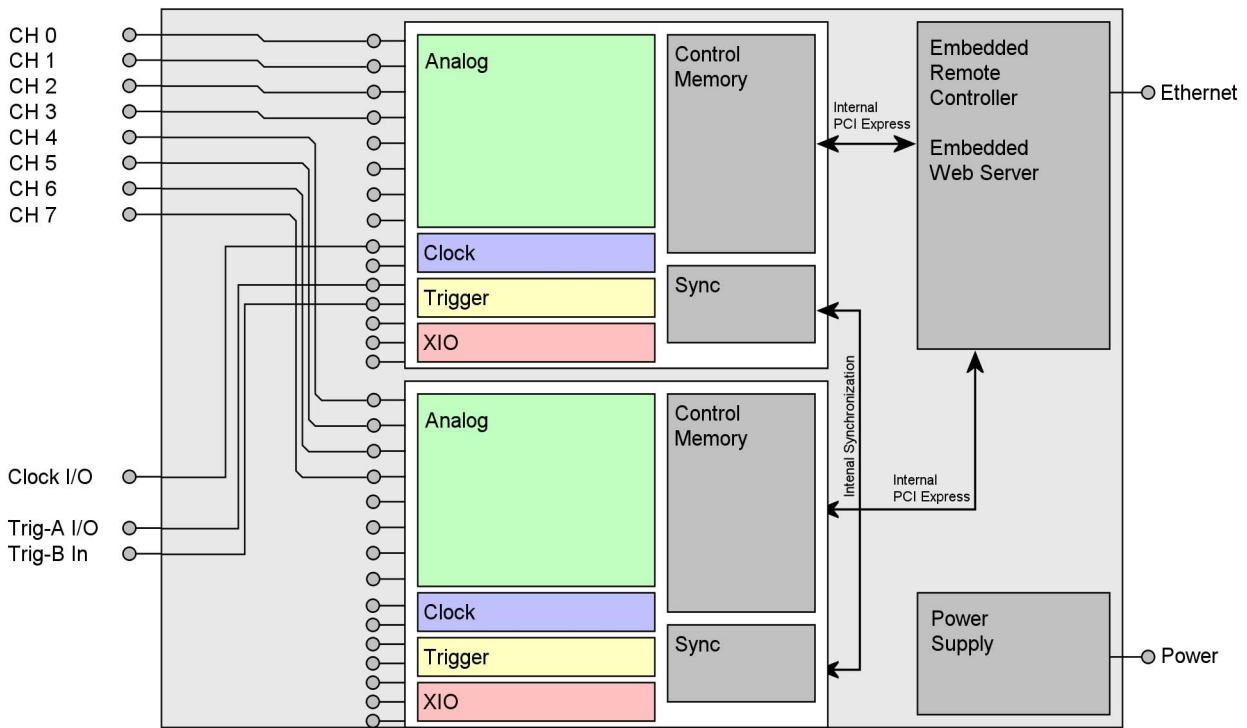

Block diagram of generatorNETBOX module DN2.60x

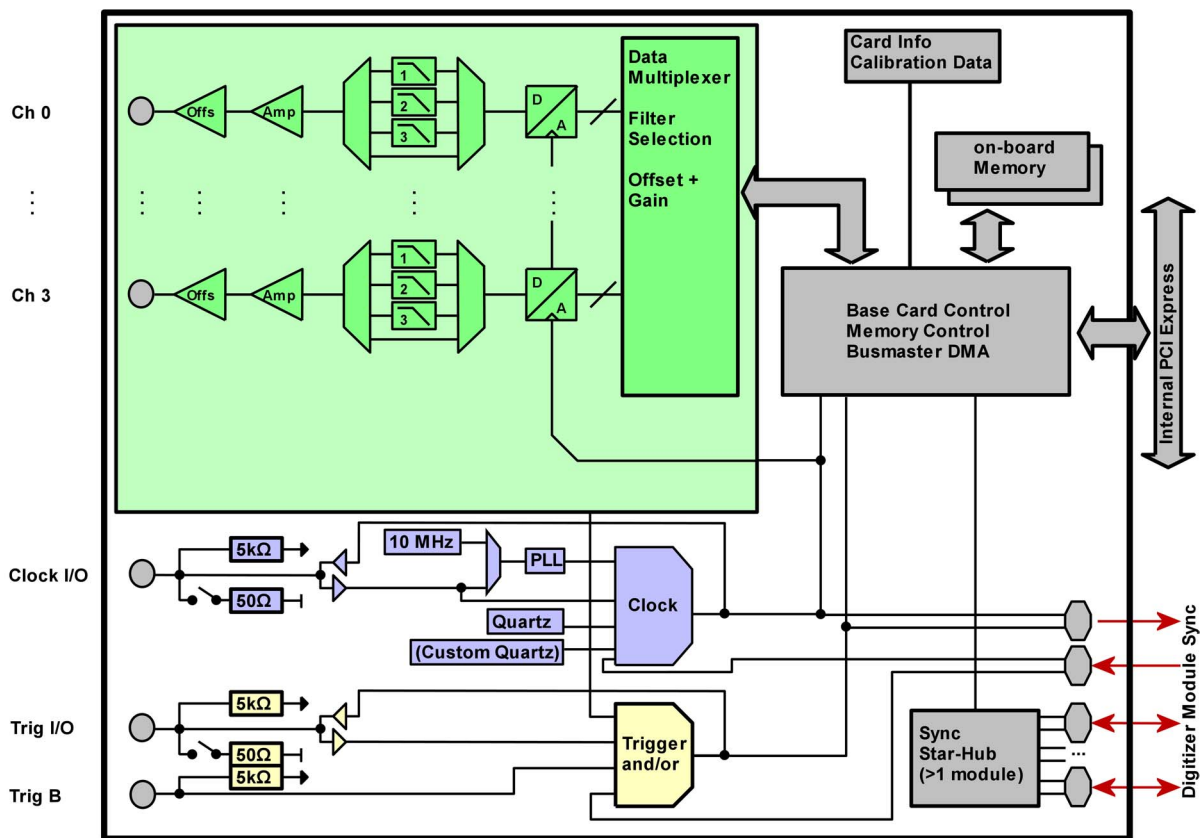

Order Information

The generatorNETBOX is equipped with a large internal memory and supports standard replay, FIFO replay (streaming), Multiple Replay, Gated Replay, Continuous Replay (Loop), Single-Restart as well as Sequence. Operating system drivers for Windows/Linux 32 bit and 64 bit, drivers and examples for C/C++, IVI (Function Generator class), LabVIEW (Windows), MATLAB (Windows and Linux), LabWindows/CVI, .NET, Delphi, Visual Basic, Java, Python and a Professional license of the oscilloscope software SBench 6 are included.

The system is delivered with a connection cable meeting your countries power connection. Additional power connections with other standards are available as option.

generatorNETBOX DN2 - Ethernet/LXI Interface

Order no.	D/A Resolution	Bandwidth	Single-Ended Channels	Update Rate	Installed Memory	Available Memory Options
DN2.603-04	14 Bit	60 MHz	4 channels	125 MS/s (2 channels) 60 MS/s (4 channels)	1 x 512MS	1 x 1GS
DN2.603-08	14 Bit	60 MHz	8 channels	125 MS/s (4 channels) 60 MS/s (8 channels)	2 x 512MS	2 x 1GS

Options

Order no.	Option
DN2.xxx-Rack	19" rack mounting set for self mounting
DN2.xxx-Emb	Extension to Embedded Server: CPU, more memory, SSD. Access via remote Linux secure shell (ssh)
DN2.xxx-1x1GS	Memory extension to 1 x 1 GSample for 46x-04, 46x-08, 49x-04, 49x-08 versions
DN2.xxx-2x1GS	Memory extension to 2 x 1 GSample for 46x-16 and 49x-16 versions
DN2.xxx-DC12	12 VDC internal power supply. Replaces AC power supply. Accepts 9 V to 18 V DC input. Screw terminals.
DN2.xxx-DC24	24 VDC internal power supply. Replaces AC power supply. Accepts 18 V to 36 V DC input. Screw terminals
DN2.xxx-BTPWR	Boot on Power On: the digitizerNETBOX/generatorNETBOX automatically boots if power is switched on.

Calibration

Order no.	Option
DN2.xxx-Recal	Recalibration of complete digitizerNETBOX/generatorNETBOX DN2 including calibration protocol
WarrExt5	Warranty extension from 2 years standard warranty to 5 years

BNC Cables

for Connections	Connection	Length	to SMA male	to SMA female	to BNC male	to SMB female
All	BNC male	80 cm	Cab-9m-3mA-80	Cab-9m-3fA-80	Cab-9m-9m-80	Cab-9m-3f-80
All	BNC male	200 cm	Cab-9m-3mA-200	Cab-9m-3fA-200	Cab-9m-9m-200	Cab-9m-3f-200

Technical changes and printing errors possible

SBench, digitizerNETBOX and generatorNETBOX are registered trademarks of Spectrum Systementwicklung Microelectronic GmbH. Microsoft, Visual C++, Visual Basic, Windows, Windows 98, Windows NT, Window 2000, Windows XP, Windows Vista, Windows 7, Windows 8 and Windows 10 are trademarks/registered trademarks of Microsoft Corporation. LabVIEW, DASYLab, Diadem and LabWindows/CVI are trademarks/registered trademarks of National Instruments Corporation. MATLAB is a trademark/registered trademark of The Mathworks, Inc. Keysight VEE, VEE Pro and VEE OneLab are trademarks/registered trademarks of Keysight Technologies, Inc. FlexPro is a registered trademark of Weisang GmbH & Co. KG. PCIe, PCI Express and PCI-X and PCI-SIG are trademarks of PCI-SIG. LXI is a registered trademark of the LXI Consortium. PICMG and CompactPCI are trademarks of the PCI Industrial Computation Manufacturers Group. Oracle and Java are registered trademarks of Oracle and/or its affiliates. Intel and Intel Xeon are trademarks or registered trademarks of Intel Corporation. AMD and Opteron are trademarks or registered trademarks of Advanced Micro Devices.